

Dolphin

LB 0063 - LB 4409

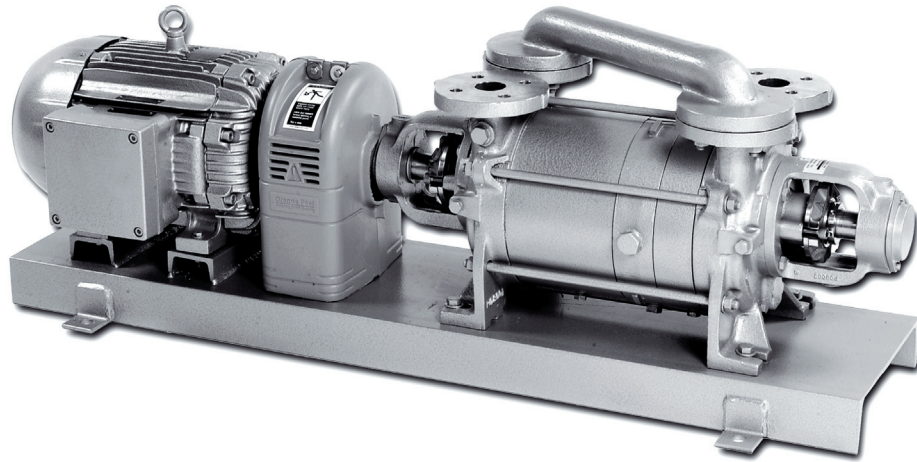

LB 0184 (shown with optional outboard bearings)

Description

Our Dolphin LB range of liquid ring vacuum pumps are well suited for wet and corrosive applications. They combine the benefits of high efficiency from a compact rugged machine, and reduced running cost from a competitive product.

Features

- Suction capacity from 38 cfm to over 2500 cfm
- Ultimate pressure of 25 torr (29 HgV)
- Available in a wide range of materials
- Minimal moving/contacting parts allowing ease of service and maintenance
- Single mechanical seals standard
- Low vibration and noise level
- Reliability
- ANSI flanges and NEMA motors
- Some models are directly interchangeable with other brands
- Low heat emission
- Oil free discharge

Liquid Ring Vacuum Pump

Operating Principle

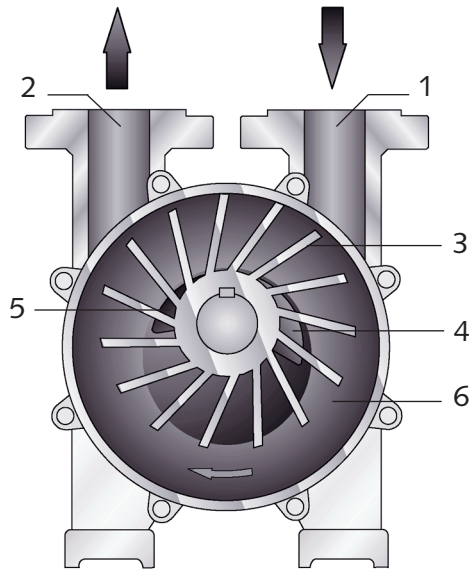

1. Inlet
2. Outlet
3. Impeller
4. Inlet Port
5. Outlet Port
6. Liquid Ring

Operating Principle

Liquid ring pumps operate with only one moving part, the impeller shaft assembly. The impeller is mounted eccentrically relative to its casing. The liquid ring is formed by the service liquid (normally water) rotating concentrically in its casing. Process gas enters through the suction port, travels between the impeller blades and is compressed prior to exhausting through the discharge port along with a quantity of service liquid.

Areas of Application

- Autoclaves
- Automotive
- Chemical Processing
- Concentration
- De-gassing
- Distillation
- Drying
- Evaporation
- Filtration
- Food Processing
- Hospitals
- Impregnation
- Milking
- Molding
- Paints
- Packaging
- Paper
- Paper, Envelopes, Converting
- Plastics
- Pharmaceutical Processing
- Power Generation
- Solvent Recovery
- Soaps
- Tobacco
- Timber Treatment
- Textiles

Features, Options, and Configurations

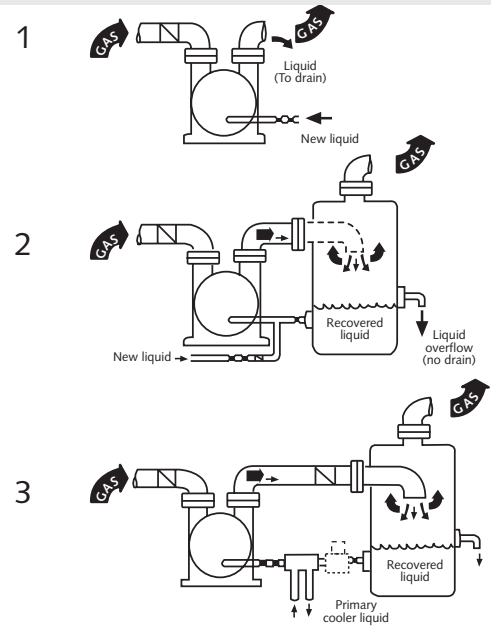
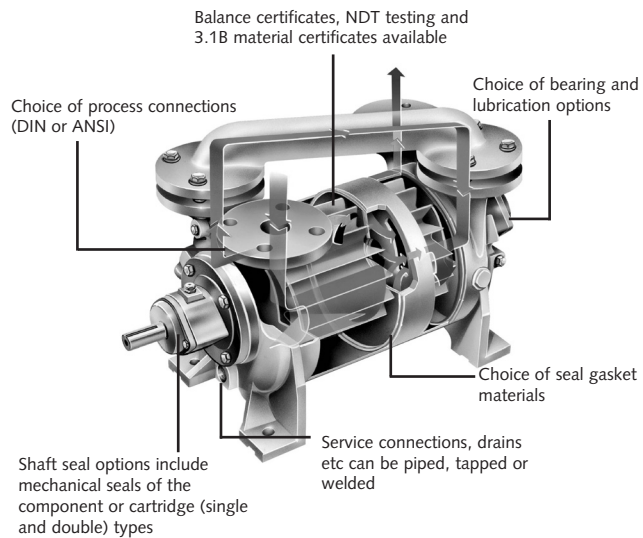

Available Options

- Various materials of construction including 316 stainless steel, bronze, etc...
- Base plate or pedestal mounting configurations
- IEC motors
- Metric connections
- System configurations (once through, partial recovery, and total recovery)
- Outboard bearing in place of standard inboard bearing
- Packed gland seal or double mechanical seal

Bearing Types

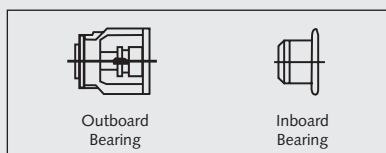

Contact Busch, Inc. Application Engineering Department for assistance in selecting and configuring a pump suited for your needs.

System Configurations

1. Once Through System - No Recovery

The service liquid comes from a fresh supply, passes only once through the pump and is discharged to an open drain.

2. Partial Recovery System

Within this system the service liquid is discharged to a vessel which allows separation of the gas and liquid. A portion of the discharged liquid is returned to the pump's service fluid inlet together with a fresh liquid supply. This reduces the amount of fresh liquid required.

3. Total Recovery System

This system provides for total recirculation of the service liquid and is preferable when liquid is in short supply or where there is a risk of contamination. A heat exchanger is added to the system to remove the heat of compression prior to re-use of the service liquid.

Liquid Ring Vacuum Pump

Technical Data Dolphin LB 0063 - 0726

Pumping Speed vs. Inlet Pressure

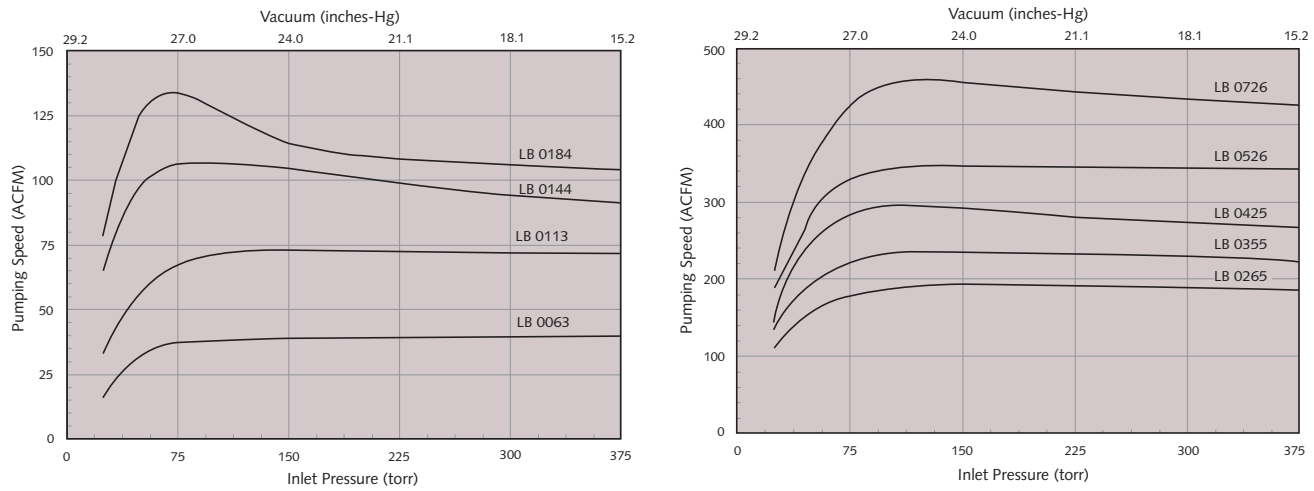

All data based on dry air @ 68°F, and water as sealing fluid with 59°F ring temperature.

Technical Data		LB 0063	LB 0113	LB 0144	LB 0184	LB 0265	LB 0355	LB 0425	LB 0526	LB 0726
Nominal pumping speed	ACFM	38	71	106	132	191	235	294	341	453
Ultimate pressure	Torr	25	25	25	25	25	25	25	25	25
Motor size	HP	7.5	7.5	7.5	10	20	20	25	40	50
Nominal motor speed	RPM	1750	1750	1750	1750	1750	1750	1750	1750	1750
Typical service liquid flow	GPM	6	6	7	8	10	11	13	27	27
Max. gas inlet temperature	°F	176	176	176	176	176	176	176	176	176
Approximate weight (bare shaft module)	Lbs.	159	161	214	245	342	377	397	582	613
Sound level rating*	dB(A)	72	72	72	72	75	75	75	75	75

Performance data based on ambient conditions of 14.7 PSIA and 70° F, and have a tolerance of +/- 10%.

*DIN EN ISO 2151



Technical Data Dolphin LB 0857 - 4409

Pumping Speed vs. Inlet Pressure

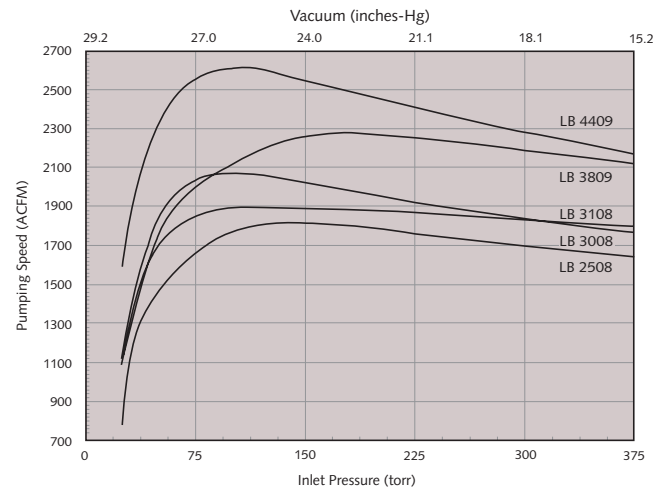
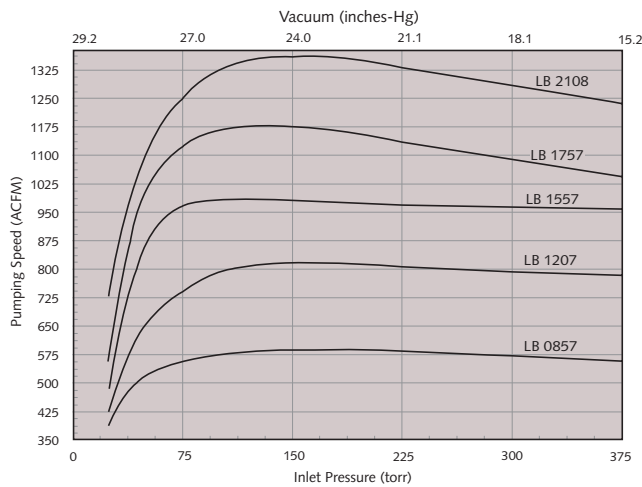

All data based on dry air @ 68°F, and water as sealing fluid with 59°F ring temperature.

Technical Data		LB 0857	LB 1207	LB 1557	LB 1757	LB 2108	LB 2508	LB 3008	LB 3108	LB 3809	LB 4409
Nominal pumping speed	ACFM	589	812	995	1177	1354	1819	1883	2060	2237	2590
Ultimate pressure	Torr	25	25	25	25	25	25	25	25	25	25
Motor size	HP	60	75	100	125	125	150	200	200	200	250
Nominal motor speed	RPM	1150	1150	1150	1150	880	880	880	880	700	700
Typical service liquid flow	GPM	31	33	35	35	42	42	46	53	75	79
Max. gas inlet temperature	°F	176	176	176	176	176	176	176	176	176	176
Approximate weight (bare shaft module) Lbs.		1190	1323	1510	1698	3219	3483	3748	4277	4630	4850
Sound level rating*	dB(A)	77	77	77	77	79	79	79	79	85	85

Performance data based on ambient conditions of 14.7 PSIA and 70° F, and have a tolerance of +/- 10%.

*DIN EN ISO 2151

Liquid Ring Vacuum Pump

Dimensions

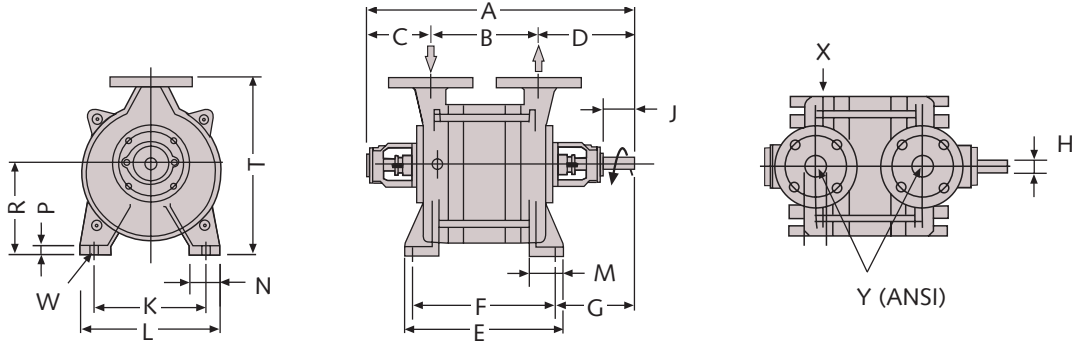

Dimensions	A	B	C	D	E	F	G	H	J	K	L	M	N	P	R	S	T	V	W	X	Y
LB 0063	26 ¹ / ₈	9 ¹ / ₂	7 ¹ / ₄	9 ³ / ₈	13 ¹ / ₈	12	8 ¹ / ₈	7 ⁷ / ₈	11 ⁵ / ₁₆	7 ⁷ / ₈	9 ¹³ / ₁₆	2 ³ / ₈	2 ³ / ₁₆	5 ⁵ / ₈	6 ¹ / ₂	-	12 ⁵ / ₈	-	9 ⁹ / ₁₆	1 ¹ / ₂ " NPT	1 ¹ / ₂
LB 0113	27 ¹¹ / ₁₆	11 ¹ / ₈	7 ¹ / ₄	9 ³ / ₈	14 ³ / ₄	13 ⁹ / ₁₆	8 ¹ / ₈	7 ⁷ / ₈	11 ⁵ / ₁₆	7 ⁷ / ₈	9 ¹³ / ₁₆	2 ³ / ₈	2 ³ / ₁₆	5 ⁵ / ₈	6 ¹ / ₂	-	12 ⁵ / ₈	-	9 ⁹ / ₁₆	1 ¹ / ₂ " NPT	1 ¹ / ₂

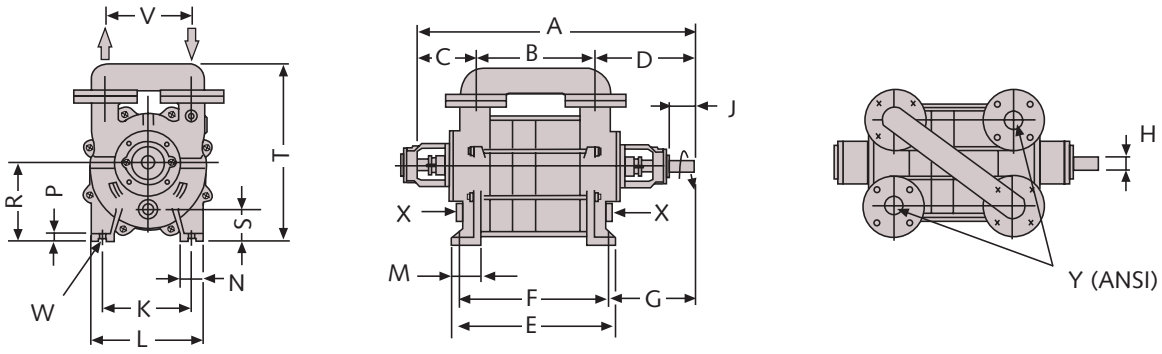

Dimensions	A	B	C	D	E	F	G	H	J	K	L	M	N	P	R	S	T	V	W	X	Y
LB 0144	30	10 ¹¹ / ₁₆	8 ¹ / ₂	10 ¹³ / ₁₆	15 ¹ / ₂	14 ⁵ / ₁₆	9	1	2 ³ / ₁₆	8 ¹ / ₄	10 ⁵ / ₈	2 ³ / ₄	2 ¹ / ₂	11 ¹ / ₁₆	6 ⁷ / ₈	2 ⁹ / ₁₆	15 ¹⁵ / ₁₆	6 ⁵ / ₁₆	9 ⁹ / ₁₆	3 ³ / ₄ " NPT	2
LB 0184	32 ³ / ₈	13 ¹ / ₁₆	8 ¹ / ₂	10 ¹³ / ₁₆	17 ⁷ / ₈	16 ¹¹ / ₁₆	9	1	2 ³ / ₁₆	8 ¹ / ₄	10 ⁵ / ₈	2 ³ / ₄	2 ¹ / ₂	11 ¹ / ₁₆	6 ⁷ / ₈	2 ⁹ / ₁₆	15 ¹⁵ / ₁₆	6 ⁵ / ₁₆	9 ⁹ / ₁₆	3 ³ / ₄ " NPT	2
LB 0265	35 ³ / ₈	12 ³ / ₈	9 ¹⁵ / ₁₆	13	16 ⁷ / ₈	15 ⁹ / ₁₆	11 ⁷ / ₁₆	1 ³ / ₈	2 ³ / ₄	9 ¹ / ₄	11 ¹³ / ₁₆	2 ¹⁵ / ₁₆	2 ⁹ / ₁₆	1 ³ / ₁₆	8 ¹ / ₄	3 ³ / ₈	20 ¹ / ₂	9 ¹ / ₁₆	11 ¹ / ₁₆	1" NPT	2
LB 0355	37 ¹¹ / ₁₆	14 ³ / ₄	9 ¹⁵ / ₁₆	13	19 ¹ / ₄	17 ¹⁵ / ₁₆	11 ⁷ / ₁₆	1 ³ / ₈	2 ³ / ₄	9 ¹ / ₄	11 ¹³ / ₁₆	2 ¹⁵ / ₁₆	2 ⁹ / ₁₆	1 ³ / ₁₆	8 ¹ / ₄	3 ³ / ₈	20 ¹ / ₂	9 ¹ / ₁₆	11 ¹ / ₁₆	1" NPT	2
LB 0425	39 ⁵ / ₁₆	16 ⁵ / ₁₆	9 ¹⁵ / ₁₆	13	20 ¹³ / ₁₆	19 ¹ / ₂	11 ⁷ / ₁₆	1 ³ / ₈	2 ³ / ₄	9 ¹ / ₄	11 ¹³ / ₁₆	2 ¹⁵ / ₁₆	2 ⁹ / ₁₆	1 ³ / ₁₆	8 ¹ / ₄	3 ³ / ₈	20 ¹ / ₂	9 ¹ / ₁₆	11 ¹ / ₁₆	1" NPT	2
LB 0526	41 ³ / ₁₆	17 ⁵ / ₁₆	10 ¹ / ₁₆	13 ¹³ / ₁₆	22 ⁹ / ₁₆	21 ³ / ₈	11 ¹³ / ₁₆	1 ³ / ₄	3 ³ / ₈	12 ⁵ / ₈	15 ³ / ₄	3 ¹ / ₈	3 ¹ / ₄	11 ¹ / ₁₆	9 ¹³ / ₁₆	3 ³ / ₄	23 ³ / ₈	11 ⁷ / ₁₆	1 ³ / ₁₆	1 ¹ / ₄ " NPT	3 ¹ / ₂
LB 0726	45 ⁷ / ₈	22 ¹ / ₁₆	10 ¹ / ₁₆	13 ¹³ / ₁₆	27 ⁵ / ₁₆	26 ¹ / ₈	11 ¹³ / ₁₆	1 ³ / ₄	3 ³ / ₈	12 ⁵ / ₈	15 ³ / ₄	3 ¹ / ₈	3 ¹ / ₄	11 ¹ / ₁₆	9 ¹³ / ₁₆	3 ³ / ₄	23 ³ / ₈	11 ⁷ / ₁₆	1 ³ / ₁₆	1 ¹ / ₄ " NPT	3 ¹ / ₂
LB 0857	50 ¹ / ₂	21 ⁷ / ₁₆	11 ¹⁵ / ₁₆	17 ¹ / ₁₆	27 ³ / ₄	26	14 ³ / ₄	2 ³ / ₈	4 ³ / ₄	15 ³ / ₄	18 ⁷ / ₈	4 ⁵ / ₁₆	3 ¹⁵ / ₁₆	1	12 ⁵ / ₈	3 ⁹ / ₁₆	27 ¹⁵ / ₁₆	14 ⁹ / ₁₆	7 ⁷ / ₈	1 ¹ / ₂ " NPT	4
LB 1207	56 ³ / ₈	27 ³ / ₈	11 ¹⁵ / ₁₆	17 ¹ / ₁₆	33 ¹¹ / ₁₆	31 ⁷ / ₈	14 ³ / ₄	2 ³ / ₈	4 ³ / ₄	15 ³ / ₄	18 ⁷ / ₈	4 ⁵ / ₁₆	3 ¹⁵ / ₁₆	1	12 ⁵ / ₈	3 ⁹ / ₁₆	27 ¹⁵ / ₁₆	14 ⁹ / ₁₆	7 ⁷ / ₈	1 ¹ / ₂ " NPT	4
LB 1557	60 ⁵ / ₁₆	31 ⁵ / ₁₆	11 ¹⁵ / ₁₆	17 ¹ / ₁₆	37 ⁵ / ₈	35 ¹³ / ₁₆	14 ³ / ₄	2 ³ / ₈	4 ³ / ₄	15 ³ / ₄	18 ⁷ / ₈	4 ⁵ / ₁₆	3 ¹⁵ / ₁₆	1	12 ⁵ / ₈	3 ⁹ / ₁₆	27 ¹⁵ / ₁₆	14 ⁹ / ₁₆	7 ⁷ / ₈	1 ¹ / ₂ " NPT	4
LB 1757	66 ¹ / ₄	37 ⁵ / ₁₆	11 ¹⁵ / ₁₆	17 ¹ / ₁₆	43 ¹ / ₂	41 ³ / ₄	14 ³ / ₄	2 ³ / ₈	4 ³ / ₄	15 ³ / ₄	18 ⁷ / ₈	4 ⁵ / ₁₆	3 ¹⁵ / ₁₆	1	12 ⁵ / ₈	3 ⁹ / ₁₆	27 ¹⁵ / ₁₆	14 ⁹ / ₁₆	7 ⁷ / ₈	1 ¹ / ₂ " NPT	4

All dimensions in inches unless otherwise noted.

Dimensions

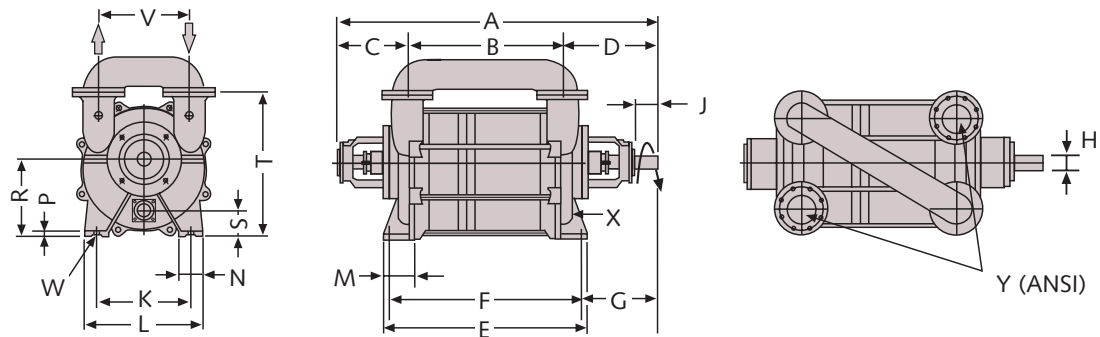

Dimensions	A	B	C	D	E	F	G	H	J	K	L	M	N	P	R	S	T	V	W	X	Y
LB 2108	76 ⁵ / ₁₆	33 ⁵ / ₈	18 ¹ / ₈	24 ¹ / ₂	44 ¹ / ₄	41 ³ / ₄	20 ¹ / ₂	3 ¹ / ₈	6 ⁵ / ₁₆	20 ¹ / ₂	25 ⁹ / ₁₆	6 ³ / ₄	5 ¹ / ₈	1 ³ / ₁₆	16 ¹⁵ / ₁₆	5 ⁵ / ₈	39 ⁷ / ₁₆	19 ¹¹ / ₁₆	1 ⁵ / ₁₆	2 ¹ / ₂ "NPT	6
LB 2508	82 ³ / ₁₆	39 ¹ / ₂	18 ¹ / ₈	24 ¹ / ₂	50	47 ⁵ / ₈	20 ¹ / ₂	3 ¹ / ₈	6 ⁵ / ₁₆	20 ¹ / ₂	25 ⁹ / ₁₆	6 ³ / ₄	5 ¹ / ₈	1 ³ / ₁₆	16 ¹⁵ / ₁₆	5 ⁵ / ₈	39 ⁷ / ₁₆	19 ¹¹ / ₁₆	1 ⁵ / ₁₆	2 ¹ / ₂ "NPT	6
LB 3008	86 ¹ / ₈	43 ⁷ / ₁₆	18 ¹ / ₈	24 ¹ / ₂	53 ¹⁵ / ₁₆	51 ⁹ / ₁₆	20 ¹ / ₂	3 ¹ / ₈	6 ⁵ / ₁₆	20 ¹ / ₂	25 ⁹ / ₁₆	6 ³ / ₄	5 ¹ / ₈	1 ³ / ₁₆	16 ¹⁵ / ₁₆	5 ⁵ / ₈	39 ⁷ / ₁₆	19 ¹¹ / ₁₆	1 ⁵ / ₁₆	2 ¹ / ₂ "NPT	6
LB 3108	87 ¹ / ₂	44 ¹³ / ₁₆	18 ¹ / ₈	24 ¹ / ₂	55 ⁵ / ₁₆	52 ¹⁵ / ₁₆	20 ¹ / ₂	3 ¹ / ₈	6 ⁵ / ₁₆	20 ¹ / ₂	25 ⁹ / ₁₆	6 ³ / ₄	5 ¹ / ₈	1 ³ / ₁₆	16 ¹⁵ / ₁₆	5 ⁵ / ₈	39 ⁷ / ₁₆	19 ¹¹ / ₁₆	1 ⁵ / ₁₆	2 ¹ / ₂ "NPT	6

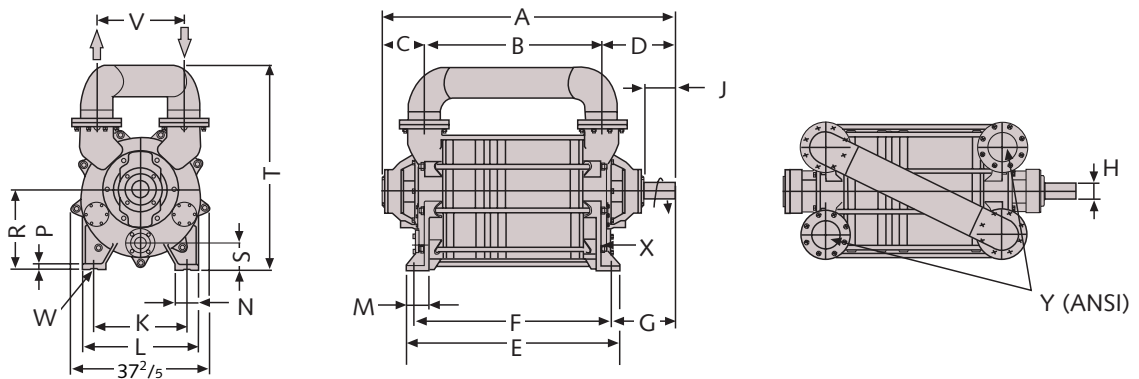

Dimensions	A	B	C	D	E	F	G	H	J	K	L	M	N	P	R	S	T	V	W	X	Y
LB 3809	79 ³ / ₄	48 ¹ / ₁₆	11 ⁵ / ₈	20 ¹ / ₁₆	58 ¹ / ₈	53 ¹³ / ₁₆	17 ³ / ₁₆	4 ⁵ / ₁₆	8 ¹ / ₄	25 ³ / ₁₆	31 ² / ₄	6 ⁵ / ₁₆	6 ⁵ / ₁₆	1 ⁹ / ₁₆	21 ⁵ / ₈	7 ³ / ₁₆	55 ¹ / ₂	23 ⁵ / ₈	1 ³ / ₈	3"NPT	8
LB 4409	94 ⁵ / ₈	53	11 ⁵ / ₈	20 ¹ / ₁₆	63 ¹ / ₁₆	58 ³ / ₄	17 ³ / ₁₆	4 ⁵ / ₁₆	8 ¹ / ₄	25 ³ / ₁₆	31 ² / ₄	6 ⁵ / ₁₆	6 ⁵ / ₁₆	1 ⁹ / ₁₆	21 ⁵ / ₈	7 ³ / ₁₆	55 ¹ / ₂	23 ⁵ / ₈	1 ³ / ₈	3"NPT	8

All dimensions in inches unless otherwise noted.

Effect of Service Liquid Temperature

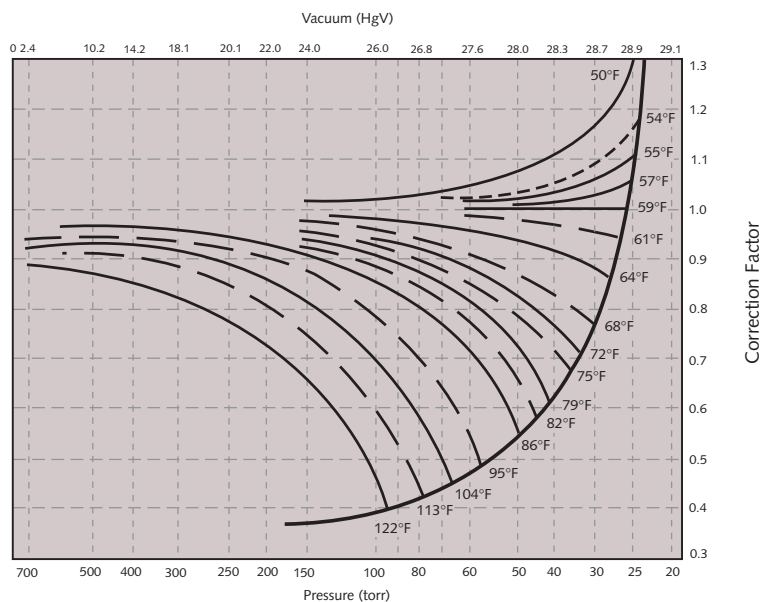

This graph is applicable when water is the service fluid. A different correction must be made for different fluids.

Capacity at 59°F x Factor = Capacity at actual seal water temperature.

Capacity Corrections

The actual capacity of a liquid ring vacuum pump is dependent upon, and therefore must be corrected for a variety of variables. The advertised capacity is only valid for the specific conditions shown with the curve. Variables affecting capacity include the type and temperature of the service fluid along with the conditions of the incoming gas load.

Service Fluid Affects

Service fluid vapor pressure effects: As a dry gas load enters the pump, the service fluid will vaporize and saturate the dry gas load. This has the effect of reducing the dry gas capacity of the pump. The advertised capacity is accounting for this already at a service

fluid temperature of 59°F. If the service fluid temperature is different than 59°F, a correction must be made and the above graph can be used to make this correction when using water as a service fluid. Fluids with a lower vapor pressure than water will have the effect of increasing the capacity and fluids with a higher vapor pressure than water will have the effect of decreasing the capacity vs. water.

Service fluid density effects: Service fluids of higher density than water will have the effect of reducing the pumps capacity.

Service fluid viscosity effects: Service fluids of higher viscosity than water will have the effect of reducing a pumps capacity.

Pumped Gas Affects

Condensable loads: If the incoming gas load includes vapors that will condense at the service fluid temperature, this will have the effect of increasing the pumps capacity.

Solubility of gas loads: Gases that are soluble in the service fluid will dissolve into the service fluid near the pump discharge and revaporize near the inlet side. This will have the effect of decreasing the capacity of the pump.

Contact Busch Engineering for assistance in determining the above and additional affects.

Busch - all over the world in industry

ISO 9001-2000 Registered Company

Busch, Inc. 516 Viking Drive Virginia Beach, VA 23452
Phone (757) 463-7800 FAX (757) 463-7407

www.buschpump.com
1-800-USA-PUMP

